

K_r

ALIGNMENT PROCEDURE
SKY CHALLENGER II
Models S-18 SX-18



the hallicrafters inc.
2611 INDIANA AVENUE
CHICAGO

RADIO EN GROS
JOHN LAY
HIRSCHENGRABEN 40
LUZERN TEL. 29944

01273818

THE FOLLOWING MEASUREMENTS MADE WITH 1000 OHMS PER VOLT METER AND TAKEN FROM THE POINT INDICATED TO GROUND WITH THE AVC SWITCH IN THE "ON" POSITION. ANTENNA AND GROUND DISCONNECTED AND R. F. AND A. F. GAIN CONTROLS SET AT MAXIMUM. LINE VOLTAGE OF 115 AT THE TIME THESE MEASUREMENTS WERE TAKEN. NORMAL TOLERANCE ALLOWS VARIATIONS OF PLUS OR MINUS 10% FROM THE VALUES INDICATED. "DL" INDICATES A DEAD LUG BUT WILL INDICATE VOLTAGE WHEN USED AS A TIE.

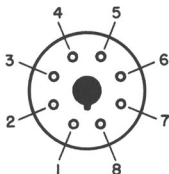

BOTTOM VIEW OF SOCKET

| TUBE | FUNCTION | 1 | 2 | 3 | 4 | 5 | 6 | 7 | 8 |
|------|--------------------|---|---|-----|-----|-----|-------|-----|-----|
| 6K7 | R. F. AMP. | | | 260 | 125 | 5 | DL | 6.3 | 5 |
| 6L7 | MIXER | | | 260 | 105 | -6 | DL | 6.3 | 4.5 |
| 6J5G | Osc. | | | 168 | DL | -19 | DL | 6.3 | 0 |
| 6K7 | IF AMP (1) | | | 265 | 125 | 5 | DL | 6.3 | 5 |
| 6K7 | IF AMP (2) | | | 250 | 125 | 5 | 260DL | 6.3 | 5 |
| 6Q7G | 2ND DET. A.V.C. | | | 75 | 1 | 1 | | 6.3 | 2 |
| 6F6G | 1ST AUDIO | | | 245 | 260 | 0 | 16DL | 6.3 | 16 |
| 6J7 | 2ND AUDIO | | | 105 | 105 | 0 | 0DL | 6.3 | 0 |

INTERMEDIATE FREQUENCY ALIGNMENT (465 KC)

HAVE THE CONTROLS SET IN THE FOLLOWING POSITIONS:

B.F.O. SWITCH "OFF"

A. F. AND R. F. GAIN CONTROLS ON FULL.

CRYSTAL PHASING CONDENSER MIDWAY (POINTER STRAIGHT UP).

A.V.C. SWITCH "OFF".

CRYSTAL SWITCH "IN".

BAND SWITCH ON #1 BAND - TUNING GANG OPEN (MINIMUM CAPACITY).

REMOVE 6J5G OSCILLATOR TUBE FROM ITS SOCKET.

REMOVE THE 6L7 GRID CAP.

PROCEDURE

CONNECT THE SIGNAL GENERATOR TO GRID OF THE 6L7 TUBE THROUGH A .1 MFD CONDENSER. TUNE THE SIGNAL GENERATOR TO 465 KC AND THEN ADJUST THE CONDENSERS ON THE INTERMEDIATE FREQUENCY TRANSFORMERS T1, T2, T3, T4, RESPECTIVELY. NOW THROW THE CRYSTAL SWITCH TO THE "OUT" POSITION AND READJUST T1 FOR MAXIMUM OUTPUT. AS AN OUTPUT INDICATOR IT IS SUGGESTED THAT A RECTIFIER TYPE METER BE USED.

ALIGNMENT USING A 465 KC CRYSTAL

SHOULD THE RECEIVER BE A CRYSTAL MODEL IT IS NECESSARY THAT THE CRYSTAL BE USED IN AN EXTERNAL OSCILLATOR IN PLACE OF A SIGNAL GENERATOR SUCH AS THE ABOVE. THE OUTPUT OF THIS CRYSTAL CONTROLLED OSCILLATOR IS THEN FED TO THE GRID OF THE 6L7 TUBE AND THE ABOVE PROCEDURE FOLLOWED. WHEN THE IF AMPLIFIER HAS BEEN ALIGNED FROM THE CRYSTAL OSCILLATOR'S OUTPUT, RE-INSERTING THE CRYSTAL IN ITS SOCKET IN THE RECEIVER WILL SHOW LITTLE DIFFERENCE IN OUTPUT WHETHER THE CRYSTAL IS "IN" OR "OUT" OF THE CIRCUIT AS INDICATED BY THE CRYSTAL SWITCH.

R. F. ALIGNMENT PROCEDURE

ON BAND #1, OR BROADCAST, USE A .0002 MFD CONDENSER IN SERIES WITH THE OUTPUT LEAD FROM THE GENERATOR TO A1 ON THE RECEIVER. ON THE OTHER BANDS A 400 OHM RESISTOR SHOULD BE USED. BE SURE THE JUMPER FROM THE DOUBLET, OR A2 POST, TO GROUND REMAINS CONNECTED WHEN ALIGNING THE RECEIVER.

ALL PAD ADJUSTMENTS (LOCATED ON THE TOP OF THE CHASSIS) ARE FOR THE LOW FREQUENCY ENDS OF THE BANDS.

ALL TRIMMER ADJUSTMENTS (LOCATED ON THE BOTTOM OF THE CHASSIS) ARE FOR THE HIGH FREQUENCY ENDS OF THE BANDS.

REDUCE R.F. GAIN CONTROL BELOW THE POINT OF BLOCKING OR OVERLOADING; ALSO BE SURE THAT THE CRYSTAL SWITCH IS IN THE "OUT" POSITION AND THE AVC SWITCH IS IN THE "OFF" POSITION.

BE SURE TO CHECK IMAGES - IMAGES WILL FALL A LITTLE LESS THAN 1 MC LOWER IN FREQUENCY ON BANDS 1 TO 4 INCLUSIVE. ON BAND 5 THE IMAGE WILL FALL ABOUT 1 MC HIGHER IN FREQUENCY THAN THE FUNDAMENTAL.

REJECTOR ADJUSTMENT - ON BANDS 1, 2 AND 3 THE REJECTOR CIRCUIT SHOULD BE LEFT AT 34 MC. ON BANDS 4 AND 5 THE REJECTOR IS IN THE CIRCUIT. CARE SHOULD BE EXERCISED TO SEE THAT THE REJECTOR CIRCUIT IS NOT ADJUSTED SO THAT IT WILL REJECT THE SIGNAL FREQUENCY. IF THIS OCCURS VERY LOW SENSITIVITY WILL RESULT WHICH CAN BE CURED BY DETUNING THE REJECTOR ABOUT 1 MC.

WHEN ALIGNING THE R.F. END OF THE RECEIVER THE TUNING GANG SHOULD BE ROCKED BACK AND FORTH ACROSS THE SIGNAL SO THAT YOU ARE SURE YOUR ADJUSTMENTS ARE SUCH THAT YOU HAVE OBTAINED MAXIMUM GAIN AND ACCURATE TRACKING.

NOTE #1 HARMONICS OF SUITABLE FREQUENCIES MAY BE USED IF THE FOLLOWING FREQUENCIES SUGGESTED ARE NOT AVAILABLE.

NOTE #2 IT IS NECESSARY TO REPEAT EACH PAIR OF OPERATIONS SEVERAL TIMES UNTIL NO CHANGE IS NOTED.

| OPR. | BAND | RECEIVER DIAL SETTING | SIGNAL GENERATOR FREQUENCY | ADJUST Osc. WITH | TRIMMERS R. F. & MIXER WITH | ADJUST Osc. PAD WITH | SET REJECTOR DIAL AT |
|---------|--------|-----------------------------|----------------------------------|------------------------|--------------------------------------|-------------------------------|----------------------------|
| 1 2 | 1 1 | 600kc 1100kc | 600kc 1100kc | ----- CA | ----- Cc - CB | C38 ----- | ----- ----- |
| 3 4 | 2 2 | 1300kc 2600kc | 1300kc 2600kc | ----- Cd | ----- CF - CE | C43 ----- | ----- ----- |
| 5 6 | 3 3 | 3000kc 6000kc | 3000kc 6000kc | ----- Ce | ----- CI - CH | C42 ----- | ----- ----- |
| 7 8 | 4 4 | 7000kc 14000kc | 7000kc 14000kc | ----- CJ | ----- CL - CK | C41 ----- | 9 mc 14mc |
| 9 10 | 5 5 | 17000kc 34000kc | 17000kc 34000kc | ----- CM | ----- Co - CN | C40 ----- | 24mc 34mc |

IT IS HELPFUL TO REMEMBER THAT THE CARTRIDGE TYPE AIR TRIMMING CONDENSERS WILL SHOW AN INCREASE OF CAPACITY WHEN THE SCREW IS ROTATED COUNTER-CLOCKWISE.

WHEN MAKING ADJUSTMENTS ON THIS RECEIVER IT IS SUGGESTED THAT GAIN BE CONTROLLED BY USING THE R.F. GAIN CONTROL ONLY. LEAVE THE A.F. GAIN CONTROL ON FULL AT ALL TIMES.

TO MAKE A RAPID CHECK OF THE RECEIVER REMOVE THE GRID CAP OF THE 6Q7 TUBE AND TOUCH THE GRID OF THE TUBE WITH YOUR FINGER. IF A LOUD HUM IS HEARD THE AUDIO END OF THE RECEIVER IS OK.

DEAD SET. CHECK BIAS ON THE R. F. TUBES. IF THIS BIAS IS TOO HIGH CHECK THE R.F. GAIN CONTROL FOR AN OPEN CIRCUIT. ADDITIONALLY, CHECK THE PLATE AND SCREEN VOLTAGE OF THE R.F. TUBES - (SEE CHART). CHECK B PLUS FOR A SHORT TO GROUND - IF SO CHECK ALL TUBES.

IF THE TUNING GANG IS NOISY WHEN THE SET IS JARRED, INCREASE THE TENSION ON THE GANG WIPERS.

NOISY COIL ASSEMBLY - CHECK SWITCH CONTACTS. ALSO CHECK THE TRIMMERS ON THE PARTICULAR BAND IN WHICH NOISE OCCURS. IT IS POSSIBLE THAT THE TRIMMER HAS DEVELOPED A PARTIAL SHORT.

IF LOW SIGNAL AND HIGH NOISE LEVEL DEVELOPS, REPLACE THE 6L7 TUBE.

DEAD BEAT OSCILLATOR - IF THE 6J7 SHOULD SHORT TO GROUND THE BEAT OSCILLATOR WILL BE DEFECTIVE. CHECK B PLUS TO B0 COIL FOR A GROUND. IN MOST CASES A NEW 6J7 WILL CORRECT A DEAD B0.

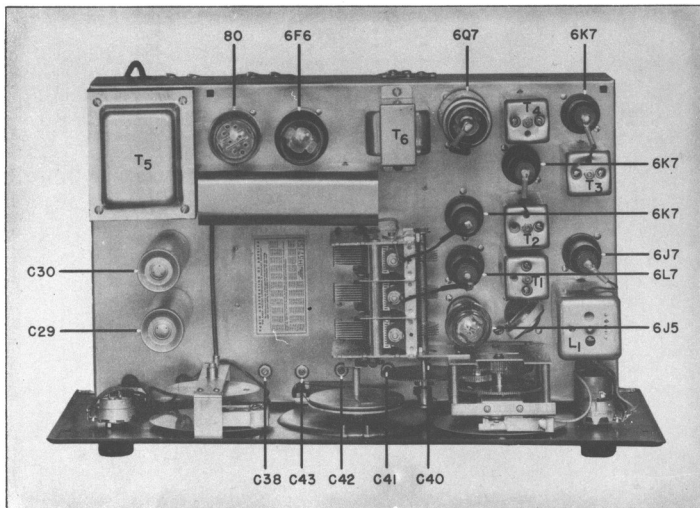
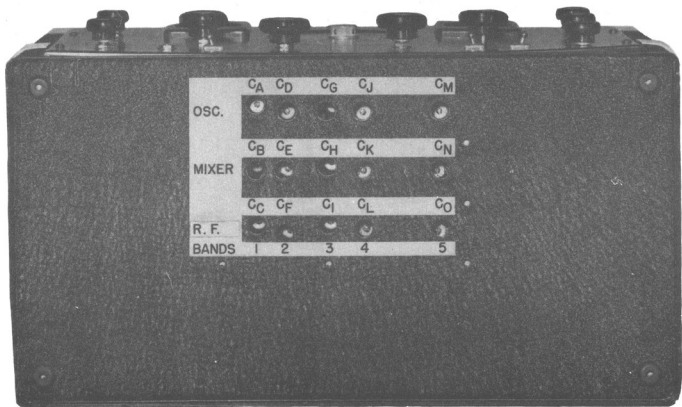

CONDENSERS

| | | | | | | | | |
|-----|--------|------|----------|----------|--------------|--|--|-----|
| C1 | 250 | MMFD | | | | | | |
| C2 | 250 | " | | | | | | |
| C3 | 250 | " | | | | | | |
| C4 | 15 | " | AIR | VARIABLE | | | | |
| C5 | .002 | MFD | | | | | | |
| C6 | .002 | MFD | 400 | VOLT | MICA | | | |
| C7 | .25 | " | 200 | " | | | | |
| C8 | .002 | " | " | " | " | | | |
| C9- | .05 | " | " | " | " | | | |
| C10 | .002 | " | " | " | " | | | |
| C11 | .05 | " | 400 | " | | | | |
| C12 | 50 | MMFD | | | " | | | |
| C13 | 25 | " | AIR | VARIABLE | | | | |
| C14 | .02 | MFD | 200 | VOLT | | | | |
| C15 | .25 | " | 400 | " | | | | |
| C16 | .02 | " | 200 | " | | | | |
| C17 | .1 | " | 400 | " | | | | |
| C18 | .05 | " | " | " | | | | |
| C19 | 250 | MMFD | | | | | | |
| C20 | 500 | " | | | | | | |
| C21 | 10 | MFD | 25 | " | ELECTROLYTIC | | | |
| C22 | 250 | MMFD | | | | | | |
| C23 | .05 | MFD | 200 | " | | | | |
| C24 | .005 | " | 400 | " | | | | |
| C25 | .1 | " | " | " | | | | |
| C26 | .05 | " | " | " | | | | |
| C27 | .003 | " | | | | | | |
| C28 | 10 | " | 25 | " | " | | | |
| C29 | 16 | " | 400 | " | " | | | WET |
| C30 | 16 | " | " | " | " | | | " |
| C31 | .01 | " | " | | | | | |
| C32 | 10 | MMFD | | | | | | |
| C33 | 250 | " | | | | | | |
| C34 | .02 | MFD | " | " | | | | |
| C35 | 25 | MMFD | AIR | VARIABLE | | | | |
| C36 | 25 | " | | | | | | |
| C37 | 10 | " | | | | | | |
| C38 | 200 | " | VARIABLE | PAD | | | | |
| C39 | 25 | " | MICA | | | | | |
| C40 | .0012 | MFD | VARIABLE | PAD | | | | |
| C41 | .0011 | " | " | " | " | | | |
| C42 | .00093 | " | " | " | " | | | |
| C43 | .00039 | " | " | " | " | | | |

RESISTORS

| No. | OHMS | |
|-----|-----------|--------------------|
| R1 | 250 | |
| R2 | 125 | |
| R3 | 100,000 | |
| R4 | 30,000 | |
| R5 | 10,000 | R. F. GAIN CONTROL |
| R6 | 250 | |
| R7 | 15,000 | |
| R8 | 100,000 | |
| R9 | 600 | |
| R10 | 100,000 | |
| R11 | 30,000 | |
| R12 | 100,000 | |
| R13 | 100,000 | |
| R14 | 1,000 | |
| R15 | 20,000 | |
| R16 | 4,000 | |
| R17 | 500,000 | VOLUME CONTROL |
| R18 | 500,000 | |
| R19 | 1,000,000 | TONE CONTROL |
| R20 | 500,000 | |
| R21 | 100,000 | |
| R22 | 250,000 | |
| R23 | 500 | |
| R24 | 250,000 | |
| R25 | 100,000 | |
| R26 | 100,000 | |
| R27 | 50,000 | |
| R28 | 10,000 | |
| R29 | 50,000 | |

SCHEMATIC DIAGRAM - SKY CHALLENGER II - MODEL SX-18

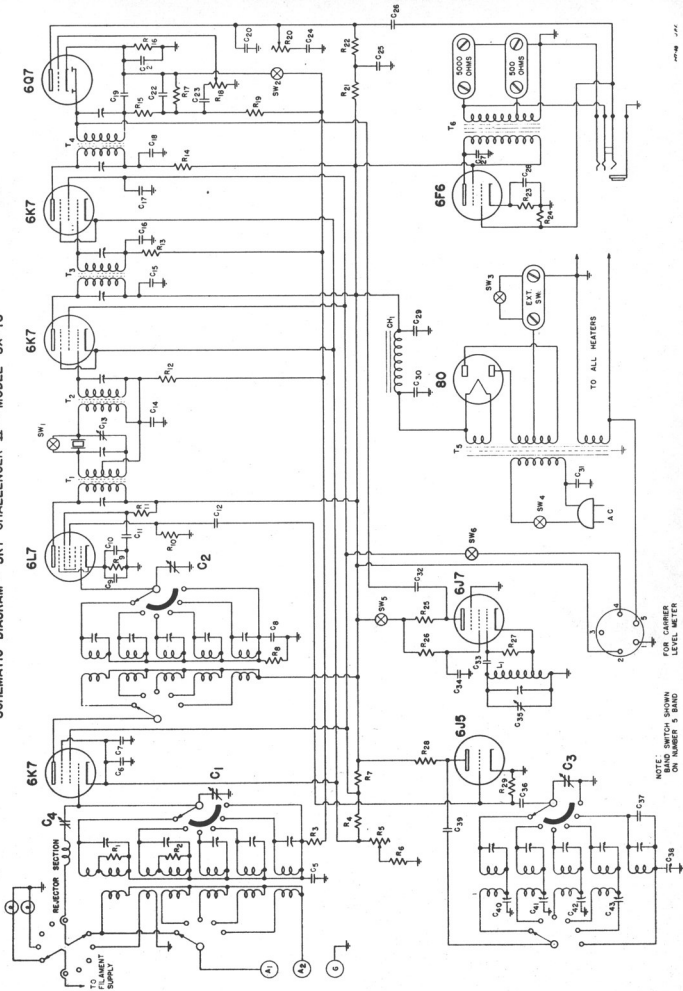

NOTE: BAND SWITCH SHOWN ON NUMBER 5 BAND

FOR CARRIER LEVEL METER