

**INSTRUCTION  
MANUAL  
FRG-7**

**SOMMERKAMP ELECTRONIC**

## TABLE OF CONTENTS

	(Page)
GENERAL DESCRIPTION .....	1
SPECIFICATION .....	2
INSTALLATION .....	3
CONTROLS AND SWITCHES .....	4
OPERATION .....	7
BLOCK DIAGRAM .....	8
CIRCUIT DESCRIPTION .....	9
ALIGNMENT AND MAINTENANCE .....	11
VOLTAGE CHART .....	13
PARTS LIST .....	14

**“WARNING : TO PREVENT FIRE OR SHOCK HAZARD, DO  
NOT EXPOSE THIS APPLIANCE TO RAIN OR MOISTURE.”**

# COMMUNICATIONS RECEIVER FRG-7



## GENERAL DESCRIPTION

The model FRG-7 is an all solid state synthesized communication receiver designed to cover the entire high frequency spectrum, 500 kHz to 29.9 MHz.

FRG-7 is a triple conversion super heterodyne receiver utilizing synthesized heterodyne oscillator known as the "Wadley Loop System" which offers unparalleled stable performance.

The calibrated dial mechanism provides 10 kHz frequency readout throughout the receiver coverage.

Good selectivity is provided for SSB, AM and CW with the utilization of a ceramic filter in the 455 kHz IF circuits.

The FRG-7 includes three step front end attenuator, amplified AGC and low-normal-high tone select switch for extreme flexibility that even the most demanding amateur, CBer, or broadcast listener desires. In addition, the large cabinet and hi-fi speaker will provide you with high quality audio output.

The FRG-7 includes a self-contained three way power supply for 100/110/117/200/220/234 volts AC 50/60 Hz, an internal battery or external 12 volt DC. If the AC power source fails, the unit switches automatically to an internal battery

To save battery consumption, the dial lamps can be switched off.

## SPECIFICATIONS

**Frequency Range:**

0.5 MHz ~ 29.9 MHz

**Speaker Impedance:**

4 ohms

**Type of Emission:**

AM, SSB (USB or LSB), CW

**Audio Output:**

2 watts

**Sensitivity:**

SSB/CW: Better than  $0.7 \mu\text{V}$  at S/N 10 dB

AM : Better than  $2 \mu\text{V}$  at S/N 10 dB

**Power Requirement:**

100/110/117/200/220/234 volts AC 50/60

Hz, 12 volts DC external or internal dry cell

UM-1 x 8

**Selectivity:**

$\pm 3$  kHz at  $-6$  dB,  $\pm 7$  kHz at  $-50$  dB

**Power Consumption:**

AC 14VA

**Stability:**

Less than  $\pm 500$  Hz at any 30 minutes after warm up

**Size:**

340 (W), 153 (H), 285 (D) mm

**Antenna Impedance:**

High impedance for 0.5 MHz ~ 1.6 MHz

50 ohm unbalanced for 1.6 MHz ~ 29.9 MHz

**Weight:**

Approx. 7 kg without batteries

## SEMICONDUCTORS COMPLEMENTS

**IC:**

AN-214	1	SN76514	1
--------	---	---------	---

**FET:**

3SK-40	3	2SK19	6
--------	---	-------	---

**Transistor:**

2SC372	8	2SC784	4
--------	---	--------	---

2SD313	1		
--------	---	--	--

**Diode:**

1N60AM	9	1S1555	2
--------	---	--------	---

V06B	3		
------	---	--	--

**Zener Diode:**

WZ-110	1	BZ091	1
--------	---	-------	---

## INSTALLATION

Carefully remove the FRG-7 receiver from the carton and examine it for any physical damage.

Should any be apparent immediately notify the carrier stating the damage in detail. Save the carton and packing materials for future use.

### Location:

In general, the location of the FRG-7 is not critical, however, it is recommended that excessively warm location be avoided.

### POWER REQUIREMENT

The FRG-7 is supplied with a multi-voltage power transformer (export model only) and can be operated in many areas of the world where supply voltage may differ from your local supply voltage. Therefore before connecting the AC cord to the power outlet, be sure that the voltage marked on the rear of the receiver agrees with the local AC supply voltage.

### CAUTION

PERMANENT DAMAGE WILL RESULT IF IMPROPER AC SUPPLY VOLTAGE IS APPLIED TO THE RECEIVER.

The FRG-7 will operate satisfactorily from any 12 volt, negative ground battery source by connecting the DC power cord (plug is supplied) to the rear panel receptacle. When making connections to the battery, be certain that the inner conductor is connected to the positive (+) and the outer conductor is connected to the negative (-) terminals of the battery. Reversed connection could permanently damage the receiver circuit.

The FRG-7 will also operate from eight dry cells in the built-in dry cell pack. (Cells are not supplied.) If the AC supply fails, the dry cell supply is automatically connected to the circuit.

The following Table 1 shows the power supply combination of FRG-7.

Power Source	1	2	3	4	5	6	7
AC Supply	○	—	—	○	○	○	—
External DC	—	○	—	×	—	×	○
Internal DC	—	—	○	—	×	×	×

- Power source in use
- × Power source connected but not in use
- Power source not connected

Table 1

### ANTENNA AND GROUND

The antenna is the most important part of the communication receiver installation. The FRG-7 is designed for use with a long wire antenna for 0.5 ~ 1.6 MHz and with a resonant antenna at the operating frequency having an impedance of 50 to 75 ohms for higher frequency than 1.6 MHz. This requirement is easily met by using a center fed dipole antenna resonated to the receiving frequency and fed with coaxial cable.

The FRG-7 should be connected to a good ground. The ground lead should be connected to the terminal marked E located on the rear panel of the receiver.

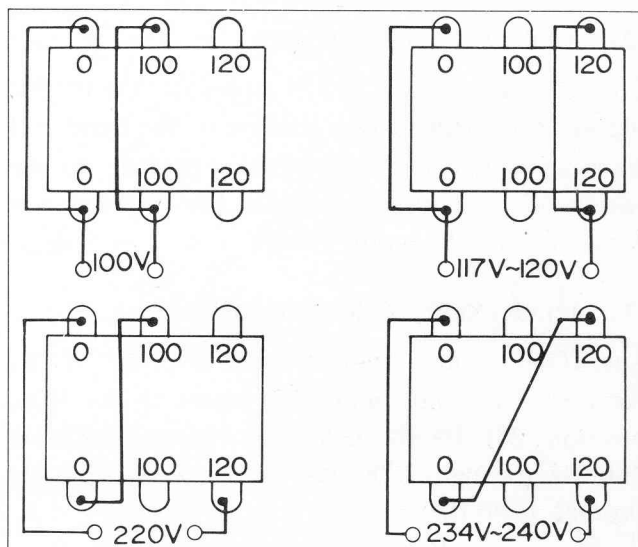
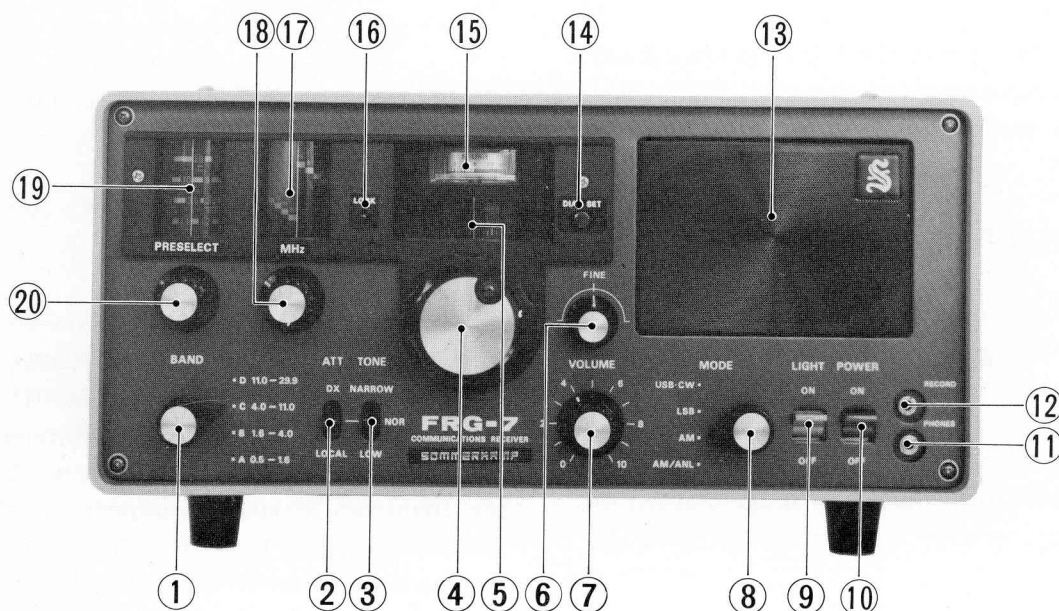

Fig.1 Transformer Primary Wiring

## CONTROLS AND SWITCHES

The FRG-7 has been designed for ease of operation. All controls have been properly adjusted at the factory. Several panel controls and switches are unusual in operation, and an improper setting may result in poor reception. The function of various controls and switches is described in the following paragraph.

Be certain that you thoroughly understand the individual function of each before operating the receiver.



### FRONT PANEL

#### (1) BAND

The BAND switch is a four position switch. The switch selects the desired frequency range.

#### (2) ATT (NOR, DX, LOCAL)

The ATT (attenuator) switch attenuates the incoming signal to prevent over-loading of the front end when an extremely strong signal is present. At the switch NOR (normal) position, the attenuator is removed from the input circuit.

#### (3) TONE (NOR, NARROW, LOW)

The TONE switch changes audio response of the receiver. The audio amplifier passes at the NOR position, 250 Hz through 3000 Hz, at NARROW 400 Hz through 2500 Hz and at LOW 250 Hz through 1500 Hz.

#### (4) (5) TUNING DIAL

The main TUNING knob determines the frequency

in combination with the BAND switch and MHz setting.

#### (6) FINE TUNING

The FINE TUNING control is used for precise tuning of the received signal. The main tuning dial is calibrated to the frequency with the fine control at centre.

#### (7) VOLUME

The VOLUME controls the audio output level from the speaker.

#### (8) MODE

The MODE switch determines the appropriate detector in use. In the USB-CW position, the USB (Upper Side Band) and code signal is heard. In the LSB position, the LSB (Lower Side Band) signal is heard. In the AM position, the amplitude modulated signal is heard and the Noise Limiter is put into the circuit in the AM/ANL position.

**(9) LIGHT**

This switch is used to turn off the lamp so as to save the current drain when the FRG-7 is operated from internal dry cells.

**(10) POWER**

This switch turns off the supply voltage for both AC and DC operation.

**(11) PHONES**

Phone jack is provided for private listening and the speaker is disconnected when the plug is inserted in this jack.

**(12) RECORD**

This jack is for recording purpose and the output level is set to approximately 50 mV regardless of setting of the VOLUME control.

**(13) SPEAKER**

Internal Speaker.

**(14) DIAL SET**

Main tuning dial calibrator.

**(15) S-METER**

The S-meter indicates the relative signal strength of the received signal. It is calibrated in S-unit from S-1 to S-9 and in dB over S-9.

**(16) LOCK**

The LOCK lamp lights up when the synthesized heterodyne oscillator is unlocked.

**(17) (18) MHz**

This MHz control synthesizes heterodyne oscillator to the harmonics of 1 MHz crystal oscillator. The scale is calibrated in MHz with the frequency showing the correct setting of the heterodyne signal.

**(19) (20) PRESELECT**

The PRESELECTOR control tunes the receiver front end. The scale is calibrated with the frequency showing the correct setting for various bands.

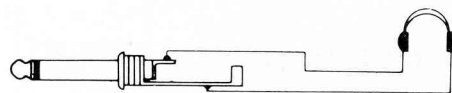
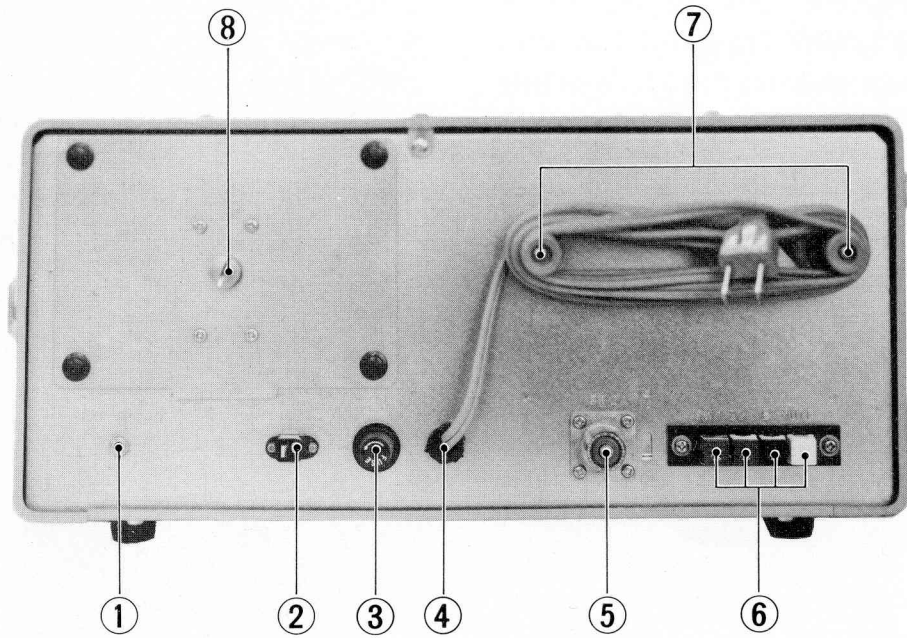

Fig. 2 Headphone Connection



**REAR PANEL CONNECTION**

**(1) EXT SP**

This jack is for connection of a 4 ohm external speaker when desired. With the plug in the S jack, the internal speaker is disconnected.

**(2) EXT DC**

Receptacle for external 12 volts DC supply.

**(3) FUSE**

Fuse for AC operation. Use 0.15 amp rating fuse.

**(4) AC cord**

Cord for AC operation.

**(5) SW2**

Coaxial connector for short wave listening.

**(6) SW, BC, E, MUTE**

SW is long wire antenna terminal for the short wave listening.

BC is long wire antenna terminal for the broadcast band listening.

E is ground connection.

MUTE is used to disable the receiver while transmitting. Connect this terminal to ground for receiver muting.

**(7) (8)**

AC cord holder and the internal battery pack.

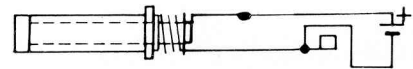

Fig.3 External Power Plug Connection



# OPERATION

## FREQUENCY SELECTION

The receiving frequency is selected by the combination of the MHz dial and main tuning dial settings.

The MHz dial selects the band at every 1 MHz and the main tuning dial selects the frequency at 10 kHz increment from 0 to 990 kHz in the band.

The combination of these controls is shown in Table 2.

## AMATEUR BAND RECEPTION

### SSB Voice Signal:

Most amateurs use LSB on frequencies lower than 10 MHz and USB on frequencies higher than 10 MHz.

Set the controls and switches as follows;

- POWER        OFF
- BAND        Desired frequency segment
- ATT         NOR
- TONE        NOR
- VOLUME     Desired listening level

	Frequency	PRESELECT	MHz	Main Dial	BAND	MODE
Amateur	kHz 1,910	2.0 1.8	2 1 0	9 1 0	B1.6~4.0	USB · CW
	3,525	3.6 3.3	4 3 2	5 2 5	B1.6~4.0	LSB
	7,050	8 7	8 7 6	0 5 0	C4.0~11.0	LSB
	14,175	15 13	15 14 13	1 7 5	D11.0~29.9	USB · CW
	21,225	23 20	22 21 20	2 2 5	D11.0~29.9	USB · CW
	28,850	30 26	29 28 27	8 5 0	D11.0~29.9	USB · CW
Medium Wave	590	0.6	1 0	5 9 0	A0.5~1.6	AM or AM/ANL
	980	1.0 0.8	1 0	9 8 0	A0.5~1.6	AM or AM/ANL
	1,170	1.2 1.0	2 1 0	1 7 0	A0.5~1.6	AM or AM/ANL
WWV/JJY	2,500	2.6 2.3	3 2 1	5 0 0	B1.6~4.0	AM or AM/ANL
	5,000	5 4	6 5 4	0	C4.0~11.0	AM or AM/ANL
	10,000	11 10 9	11 10	0	C4.0~11.0	AM or AM/ANL
	15,000	17 15	16 15 14	0	D11.0~29.9	AM or AM/ANL
Short Wave	3,925	4.0 3.6	4 3 2	9 2 5	B1.6~4.0	AM or AM/ANL
	5,980	6	6 5 4	9 8 0	C4.0~11.0	AM or AM/ANL
	9,715	10 9	9 8	7 1 5	C4.0~11.0	AM or AM/ANL
	11,705	12 11	12 11 10	7 0 5	D11.0~29.9	AM or AM/ANL
	15,120	17 15	16 15 14	1 2 0	D11.0~29.9	AM or AM/ANL
	17,880	20 17	18 17 16	8 8 0	D11.0~29.9	AM or AM/ANL
	21,550	23 20	22 21 20	5 5 0	D11.0~29.9	AM or AM/ANL

Table. 2

MODE	LSB for 160, 80 and 40 meter bands
	USB for 20, 15 and 10 meter bands
DIAL SET	Center
PRESELECT	Desired frequency. Refer to Table 2.
MHZ	" "
MAIN DIAL	" "

Turn the POWER switch on. Precisely adjust the MHz dial until the LOCK lamp turns off. Tune the main tuning dial for the desired signal until the signal is clearly heard. Use the FINE TUNING control for precise tuning. When the received signal is garbled, try the opposite sideband. When an extremely strong signal is distorted, peak the PRESELECTOR for a maximum S-meter reading.

Set the ATT switch to LOCAL position to avoid front end over loading. Set the VOLUME for desired listening level.

The amateur SSB signals cut high and low audio response, so that it may be helpful to reduce the interference by setting the TONE switch at NARROW or LOW position.

### CW (Morse Code Signal):

The code signal can be heard with the MODE switch at USB/CW position and by tuning the main tuning dial for a desired listening tone.

### BROADCAST RECEPTION

The broadcast signal is transmitted on AM mode. If impulse type noise is experienced, set the MODE switch to AM/ANL position to reduce the noise interference.

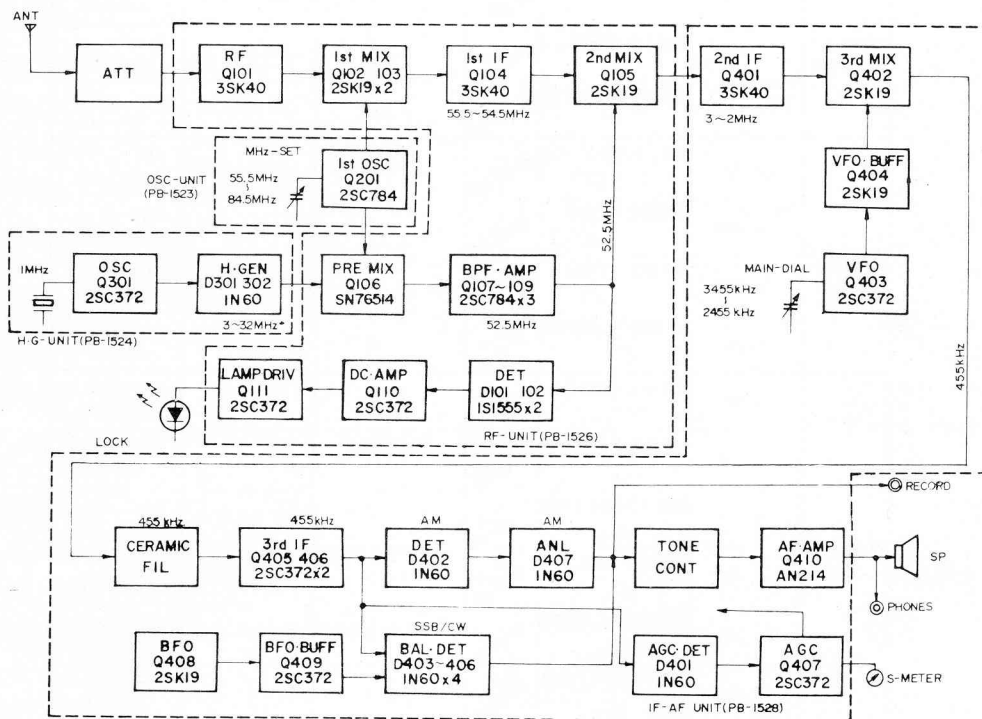

Fig.4 BLOCK DIAGRAM

## CIRCUIT DESCRIPTION

The block diagram will provide you with a better understanding of this receiver. In general, the FRG-7 is a tripple conversion super heterodyne receiver utilizing synthesized local oscillator for both the first and second mixers for drift free VFO operation.

The signal from the antenna is fed through the attenuator to the gate of the FET RF amplifier  $Q_{101}$ , **3SK40**. The amplified signal is fed through a low pass filter (cut off frequency 35 MHz) to the first balanced mixer consisting of  $Q_{102}$  and  $Q_{103}$ , **2SK19**, where the incoming signal is mixed with a signal from the heterodyne oscillator. The first heterodyne oscillator  $Q_{201}$ , **2SC784**, oscillates the signal which varies between 55.5 and 84.5 MHz.

The product of the first mixer becomes the first IF signal of 54.5 through 55.5 MHz. The first IF signal is amplified by the first IF passband amplifier  $Q_{104}$  and fed to the gate of the second mixer  $Q_{105}$ , **2SK19GR**, where the first IF signal is mixed with 52.5 MHz signal. The second mixer converts the first IF signal into the second IF signal of 2.0 through 3.0 MHz.

Synthesizer oscillator  $Q_{301}$ , **2SC372**, oscillates crystal controlled 1 MHz signal. The 1 MHz signal is then fed to the harmonic generator  $D_{301}$  and  $D_{302}$ , **1N60**, which produces 3 to 32 MHz harmonics from the 1 MHz crystal controlled signal. The harmonic signal is fed to the dual balanced pre-mixer  $Q_{106}$ , **SN76514**, where the harmonics are mixed with the signal from the first heterodyne oscillator  $Q_{201}$ . The output signal from the pre-mixer passes through the selective amplifier  $Q_{107}$ ,  $Q_{108}$  and  $Q_{109}$ , **2SC784**, which eliminates other signals except the 52.5 MHz second heterodyne signal.

A part of the output from the selective amplifier is rectified by the detectors  $D_1$  and  $D_2$ , **1S1555**, and the DC output voltage is amplified by the DC amplifier  $Q_{110}$ , **2SC372**, and then fed to the LOCK lamp driver  $Q_{111}$ , **2SC372**, which turns the LOCK lamp on when the synthesizer is unlocked.

The output signal from the first IF amplifier  $Q_{104}$  is fed to the second mixer  $Q_{105}$ , **2SK19**, where the

incoming signal is mixed with the 52.5 MHz signal from the selective amplifier. The output of the second mixer becomes second IF signal of 2.0 through 3.0 MHz. The 2.0 to 3.0 MHz IF signal is then amplified by the second IF amplifier  $Q_{401}$ , **3SK40**, and then fed to the third mixer  $Q_{402}$ , **2SK19**. The third mixer converts the second IF signal into 455 kHz third IF signal. The VFO (main tuning) signal, which varies between 2,455 kHz and 3,455 kHz, is generated by the variable frequency oscillator  $Q_{403}$ , **2SC372**, and supplied to the third mixer through the buffer amplifier  $Q_{404}$ , **2SK19**. The 455 kHz IF signal from the third mixer is fed to the ceramic filter which is tuned to 455 kHz and has  $\pm 3$  kHz passband response to eliminate interference.

The signal is then amplified by the third amplifier  $Q_{405}$  and  $Q_{406}$ , **2SC372**, and fed to the appropriate detector. The AM signal is detected by balanced diode detector  $D_{402}$ , **1N60AM**.

The balanced demodulator  $D_{403}$  through  $D_{406}$ , **1N60AM**, is used for the detection of SSB and CW signals. The carrier signal for SSB and the beat frequency signal for CW which is generated by the BFO oscillator  $Q_{408}$ , **2SK19**, are fed to the balanced demodulator through buffer amplifier,  $Q_{409}$ , **2SC372**. The MODE switch shifts the BFO frequency 3 kHz lower than LSB position for USB and CW signal reception.

A part of the output from the last IF amplifier  $Q_{406}$  is fed to the AGC (Automatic Gain Control) rectifier  $D_{401}$ , **1N60**. The rectified AGC voltage is then amplified by the AGC amplifier  $Q_{407}$ , **2SC372**, and fed to the  $Q_{101}$ ,  $Q_{401}$  and  $Q_{405}$  to control the gain of these stages automatically when the incoming signal strength is varied. Thus the receiver audio output is not effected by the variation of the input signal strength which may be caused by phasing. The S-meter is placed in the emitter circuit of  $Q_{407}$ , in which the emitter current changes in accordance with the incoming signal strength.

The detected audio output is fed through the MODE switch and the VOLUME control potentiometer  $VR_1$  to the audio amplifier integrated circuit

Q<sub>410</sub>, AN-214, which utilizes OTL (Output Transformer Less) circuit delivering 3 watts to the speaker.

The power supply is designed to operate from either 100/110/117/200/220/234 volt AC 50/60 Hz or 12 volt DC (negative ground). For AC operation, +13.5 volts are supplied from full wave rectifier D<sub>408</sub> and D<sub>409</sub>, V06B.

The 13.5 volts are used for audio amplifier stage.

The DC voltage in both AC or DC operation is supplied to the voltage regulator Q<sub>111</sub>, 2SD313, to obtain an extremely stable 10 volt DC supply which is used by the various circuits. The 10 volt DC is further regulated by zener diode D<sub>413</sub>, BZ-091, at 9 volts, and then supplied to the oscillators and harmonic generator circuits. When the AC supply fails, the DC voltage may be automatically supplied to the circuit through the diode D<sub>410</sub>, V06B, which prevents the rectified DC voltage from flowing into the battery.

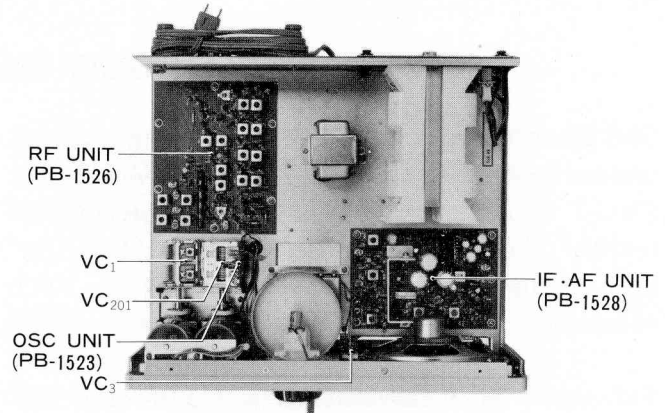

TOP VIEW

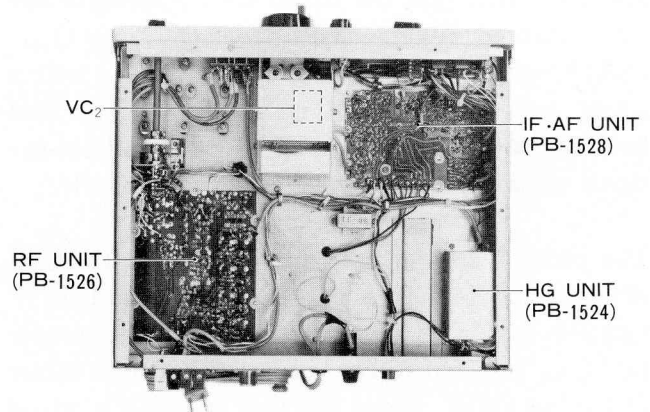

BOTTOM VIEW

FREQUENCY	1ST OSC	1ST IF (f <sub>o1</sub> -f <sub>i1</sub> )	REF FREQ (1MHz×n)	2ND OSC (f <sub>o1</sub> -f <sub>h</sub> )	2ND IF (f <sub>i1</sub> -f <sub>o2</sub> )	3RD OSC	3RD IF (f <sub>o3</sub> -f <sub>i2</sub> )
f	f <sub>o1</sub>	f <sub>i1</sub>	f <sub>h</sub>	f <sub>o2</sub>	f <sub>i2</sub>	f <sub>o3</sub>	f <sub>i3</sub>
500kHz	55.5MHz	55.0MHz	3MHz	52.5MHz	2,500kHz	2,955kHz	455kHz
1,500	56.5	55.0	4	"	2,500	2,955	"
2,500	57.5	55.0	5	"	2,500	2,955	"
3,500	58.5	55.0	6	"	2,500	2,955	"
4,500	59.5	55.0	7	"	2,500	2,955	"
5,500	60.5	55.0	8	"	2,500	2,955	"
6,500	61.5	55.0	9	"	2,500	2,955	"
7,500	62.5	55.0	10	"	2,500	2,955	"
8,500	63.5	55.0	11	"	2,500	2,955	"
9,500	64.5	55.0	12	"	2,500	2,955	"
10,000	65.5	55.5	13	"	3,000	3,455	"
11,000	66.5	55.5	14	"	3,000	3,455	"
12,000	67.5	55.5	15	"	3,000	3,455	"
13,000	68.5	55.5	16	"	3,000	3,455	"
14,000	69.5	55.5	17	"	3,000	3,455	"
15,000	70.5	55.5	18	"	3,000	3,455	"
16,000	71.5	55.5	19	"	3,000	3,455	"
17,000	72.5	55.5	20	"	3,000	3,455	"
18,000	73.5	55.5	21	"	3,000	3,455	"
19,000	74.5	55.5	22	"	3,000	3,455	"
20,000	75.5	55.5	23	"	3,000	3,455	"
21,100	76.5	55.4	24	"	2,900	3,355	"
22,200	77.5	55.3	25	"	2,800	3,255	"
23,300	78.5	55.2	26	"	2,700	3,155	"
24,400	79.5	55.1	27	"	2,600	3,055	"
25,500	80.5	55.0	28	"	2,500	2,955	"
26,600	81.5	54.9	29	"	2,400	2,855	"
27,700	82.5	54.8	30	"	2,300	2,755	"
28,800	83.5	54.7	31	"	2,200	2,655	"
29,900	84.5	54.6	32	"	2,100	2,555	"

Table 3 Frequency Relationship

## MAINTENANCE & ALIGNMENT

The FRG-7 has been carefully aligned and tested at the factory using the precise test instruments before shipment and, with normal usage, it should not require other than the usual attention given to any electronic equipment. Service or replacement of major component may require substantial realignment, however, under no circumstances, should realignment be attempted unless the operation of the receiver is fully understood and the malfunction has been fully analyzed and traced to misalignment. Service work should only be performed by experienced personnel using proper test equipment.

### TEST EQUIPMENT REQUIRED

- (1) RF Signal Generator; Hewlett-Packard Model 606A or equivalent with one volt output at an impedance of 50 ohms and a frequency coverage to 30 MHz.
- (2) Vacuum Tube Volt-Ohm Meter (VTVM): Hewlett-Packard Model 401B or equivalent VTVM with RF probe workable to 60 MHz.
- (3) Sweep Generator and Oscilloscope workable to 60 MHz.
- (4) Frequency Counter; Yaesu YC-355D or equivalent workable to 60 MHz.

### RF UNIT PB-1526

#### (1) 55 MHz Passband Circuit, $T_{105} \sim T_{108}$

Set the BAND switch to D and the MHz dial to 20 MHz position. Disconnect the antenna. Connect the sweep generator output between  $TP_{103}$  and  $TP_{102}$  (ground), and the oscilloscope input between  $TP_{104}$  and  $TP_{105}$  (ground). Set the center frequency of the sweep generator to 55 MHz and align  $T_{105}$  through  $T_{108}$  until the scope indicates the curve shown in Fig. 5. Disconnect the sweep generator and the scope.

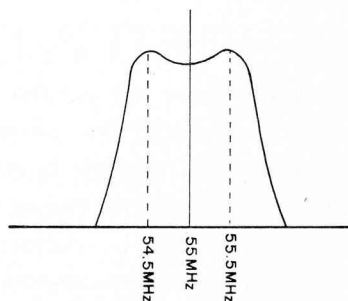

Fig.5

#### (2) Balanced Mixer, $VR_{101}$ , $TC_{105}$

Set the BAND switch to A and the MHz dial to 0. Disconnect the antenna, and connect its output to antenna terminal. Tune the receiver to the internal spurious signal at 910 kHz. Adjust  $VR_{101}$  and  $TC_{105}$  for minimum S-meter indication.

#### (3) Antenna Coil and Trimmer, $T_{101} \sim T_{104}$ , $TC_{101} \sim TC_{104}$

Connect the signal generator output to the antenna terminal  $SW_2$  and connect  $SW_1$  and BC terminals with a copper wire.

Set the signal generator to 0.5 MHz, the BAND to A and PRESELECT to 0.5. Tune the receiver to the signal generator signal. Adjust  $T_{101}$  for maximum S-meter reading. Repeat this procedure at the frequencies shown in Table 4.

FREQ	BAND	PRESELECT	ALIGNMENT
0.5MHz	A	0.5	T101
1.6MHz	A	1.6	TC101
1.6MHz	B	1.6	T102
4.0MHz	B	4.0	TC102
4.0MHz	C	4.0	T103
11.0MHz	C	11.0	TC103
11.0MHz	D	11.0	T104
30.0MHz	D	30.0	TC104

Table 4

Disconnect the signal generator and the copper wire between SW<sub>1</sub> and BC.

**(4) 52.5 MHz Selective Filter, T<sub>109</sub> ~ T<sub>116</sub>**

Disconnect the input from the oscillator unit at TP<sub>101</sub>. Connect the sweep oscillator output between TP<sub>107</sub> and ground, and the scope between TP<sub>109</sub> and ground. Set the center frequency of the sweep generator to 52.5 MHz. Adjust T<sub>109</sub> to T<sub>116</sub> until the scope screen shows the curve shown in Fig. 6.

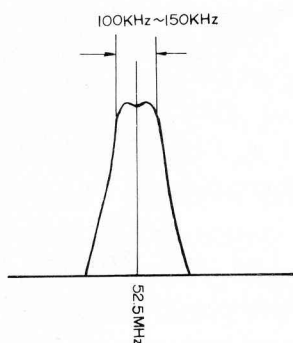

Fig. 6

Disconnect the sweep generator and scope and reconnect the wiring at TP<sub>101</sub>. After completion of the above procedures make sure that the RF voltage between TP<sub>110</sub> and ground is approximately 0.3 to 0.5 volt RMS. If not, repeat procedure.

**(5) LOCK Level, VR<sub>102</sub>**

Adjust VR<sub>102</sub> until the LOCK lamp turns off at any MHz setting of the MHz dial.

**OSC UNIT PB-1523**

**(1) MHz Setting, T<sub>201</sub>, TC<sub>201</sub>**

Connect the signal generator to antenna connector SW<sub>2</sub> and set its frequency to 3.5 MHz. Tune the receiver to the signal generator signal. Adjust T<sub>201</sub> carefully until the LOCK lamp turns off at the center of 3 MHz scale on the MHz dial. Set the signal generator frequency to 27.5 MHz and tune the receiver to this signal. Carefully adjust TC<sub>201</sub> until the LOCK lamp turns off at the center of 27 MHz scale on the MHz dial. Repeat above procedures until the LOCK lamp turns off at the center of every MHz scale, from 0 to 29 MHz. Disconnect the signal generator.

**IF AF UNIT PB-1528**

**(1) Main Tuning Dial, T<sub>403</sub>, TC<sub>403</sub>**

The following alignment should be done after warm-up of the receiver.

Set the dial hair line to the center of the dial window and FINE TUNING control to 12 o'clock position. When the main tuning dial is rotated until it stops over 1000 scale, ▲ mark should be within 5 m/m from the hair line.

Set the MODE switch to LSB and MHz dial to 0. Set the main tuning dial to 1000, then beat tone will be heard. Adjust T<sub>403</sub> for zero beat. Set the main tuning dial to 0 and adjust TC<sub>403</sub> for zero beat. Repeat above procedures until the tracking is completed.

**(2) 2nd IF Tracking, TC<sub>401</sub>, TC<sub>402</sub>, T<sub>401</sub>, T<sub>402</sub>**

Connect the signal generator to the antenna terminal SW<sub>2</sub> and set its frequency to 7.1 MHz. Tune the receiver to the signal from the signal generator. Set the output voltage from the signal generator for S-3 reading on S-meter. Adjust TC<sub>401</sub> and TC<sub>402</sub> for maximum S-meter reading. Set the signal generator to 7.9 MHz and tune the receiver to 7.9 MHz signal. Adjust T<sub>401</sub> and T<sub>402</sub> for maximum S-meter reading. Repeat these procedures until the tracking is completed.

**(3) 3rd IF, T<sub>404</sub>, T<sub>405</sub>**

Set the signal generator to 7.5 MHz and tune the receiver to this frequency. Adjust T<sub>404</sub> and T<sub>405</sub> for maximum S-meter reading. Adjust signal level so as not to saturate.

**(4) S-meter Sensitivity, VR<sub>401</sub>**

Set the output level of the signal generator to 100 dB. And tune the receiver for maximum S-meter reading. Adjust VR<sub>401</sub> for S-meter full scale. Disconnect the signal generator.

**(5) BFO Frequency, T<sub>406</sub>, TC<sub>404</sub>**

Connect a frequency counter to TP<sub>405</sub>. Set the MODE switch to LSB. Adjust T<sub>406</sub> for 457 kHz on the frequency counter reading. Set the MODE switch to USB/CW and adjust TC<sub>404</sub> for 453 kHz.

# VOLTAGE CHART

	E (S)	C (D)	B (G)		E (S)	C (D)	B (G)
Q <sub>101</sub>	1.5	4.2	G <sub>1</sub> 1.5 G <sub>2</sub> 4.0		Q <sub>301</sub>	0.2	8.0
Q <sub>102</sub>	1.6	9.0	0		Q <sub>401</sub>	2.0	9.0 G <sub>1</sub> 1.6 G <sub>2</sub> 2.7
Q <sub>103</sub>	2.2	9.0	0		Q <sub>402</sub>	1.8	9.2
Q <sub>104</sub>	0.5	9.0	G <sub>1</sub> 0 G <sub>2</sub> 4.5		Q <sub>403</sub>	1.8	3.5
Q <sub>105</sub>	2.0	9.2	0		Q <sub>404</sub>	0.5	7.8
Q <sub>107</sub>	0.7	9.2	1.3		Q <sub>405</sub>	4.3	8.5
Q <sub>108</sub>	1.1	9.2	1.7		Q <sub>406</sub>	1.4	9.1
Q <sub>109</sub>	1.4	8.8	2.0		Q <sub>407</sub>	0.01	8.7
Q <sub>110</sub>	0	0.02	0.5		Q <sub>408</sub>	1.4	6.8
Q <sub>111</sub>	0	9.5	0.02		Q <sub>409</sub>	2.2	7.0
Q <sub>201</sub>	1.8	7.7	1.2		Q <sub>411</sub>	9.5	13.5

	1	2	3	4	5	6	7	8	9	10	11	12	13	14
Q <sub>106</sub>	0	8.2	8.2	4.2	2.6	0	0	0	2.2	4.1	4.1	4.2	7.3	0
Q <sub>410</sub>	6.5	0	7.8	11.0	6.5	0	6.5	12	13.5	—	—	—	—	—

BAND.....4.0~11.0    MHz.....7    MODE.....USB/CW    Measured with VTVM    Values are in VOLTS DC

Table 5

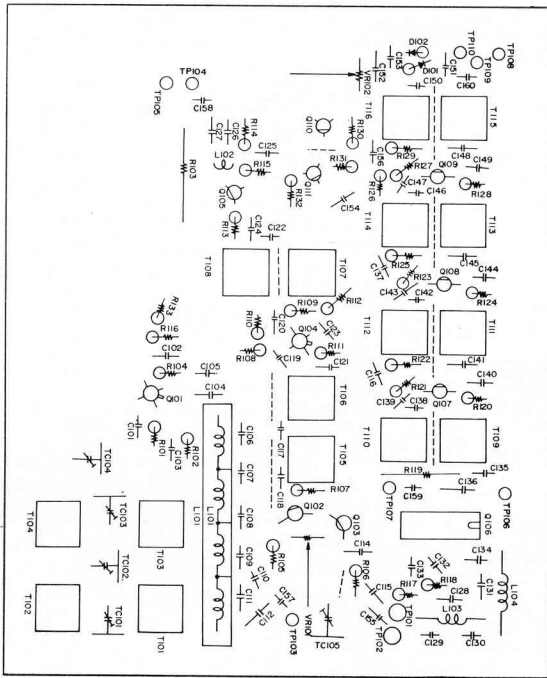

RF UNIT(PB-1526)

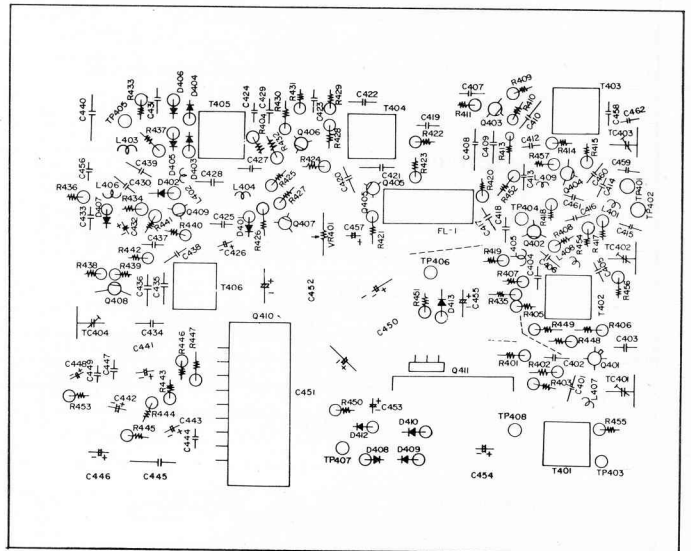

IF·AF UNIT(PB-1528)

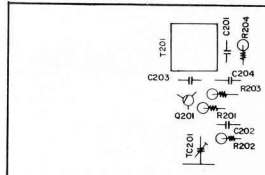

OSC UNIT(PB-1523)

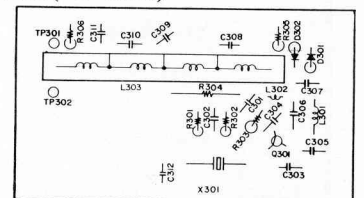

HG UNIT(PB-1524)

## PART LIST

<b>MAIN CHASSIS</b>				5	MJ-164
<b>PB</b>	<b>PRINTED CIRCUIT BOARD</b>			6 (P-6)	# 4003A
1390(A~Z)	LAMP BOARD			7	SG-8050-07
1525(A~Z)	SWITCH BOARD				
1560(A~Z)	LED BOARD				
				<b>F</b>	<b>FUSE</b>
				1	0.5A
<b>D</b>	<b>LIGHT EIMITTING DIODE</b>				
1	SL-103				
				<b>FH</b>	<b>FUSE HOLDER</b>
				1	SN-1301
<b>R</b>	<b>RESISTOR</b>				
	CARBON FILM				
1, 2	$\frac{1}{4}$ W		10 $\Omega$	<b>PL</b>	<b>PILOT LAMP</b>
5, 9	$\frac{1}{4}$ W		68 $\Omega$	1, 2, 3, 4, 5, 8	BQ041-32404A
3, 6, 12	$\frac{1}{4}$ W		100 $\Omega$	6, 7	BQ154-33811A
4	$\frac{1}{4}$ W		1K $\Omega$		
7, 11	$\frac{1}{4}$ W		3.3K $\Omega$		
10	$\frac{1}{4}$ W		10K $\Omega$		
8	$\frac{1}{4}$ W		22K $\Omega$		
	CARBON COMPOSITION				
13	$\frac{1}{2}$ W		56 $\Omega$		
14	$\frac{1}{2}$ W		68 $\Omega$		
<b>VR</b>	<b>POTENTIOMETER</b>				
1	EVL-BOAS	20A14	10KA		
<b>C</b>	<b>CAPACITOR</b>			<b>D</b>	<b>DIODE</b>
	CERAMIC DISC			101, 102	Si 1S1555
4	50WV		22PF(SL)		
3	50WV		33PF(SL)		
	MYLAR			<b>R</b>	<b>RESISTOR</b>
2	50WV		0.02 $\mu$ F		CARBON FILM
6, 7	50WV		0.047 $\mu$ F	132	$\frac{1}{4}$ W 100 $\Omega$
1	50WV		0.068 $\mu$ F	102, 103, 107, 111, 112	$\frac{1}{4}$ W 220 $\Omega$
				115, 125, 129	
				119, 122	$\frac{1}{4}$ W 330 $\Omega$
				118, 128	$\frac{1}{4}$ W 470 $\Omega$
				104, 105	$\frac{1}{4}$ W 560 $\Omega$
<b>VC</b>	<b>VARIABLE CAPACITOR</b>			117, 120, 124	$\frac{1}{4}$ W 1K $\Omega$
1	C123A119		300PF $\times$ 2	114	$\frac{1}{4}$ W 3.3K $\Omega$
2	C134ER20		320PF $\times$ 3	126	$\frac{1}{4}$ W 4.7K $\Omega$
3	TSN 150S $\times$ 05		5PF	136, 137	$\frac{1}{4}$ W 6.8K $\Omega$
				130	$\frac{1}{4}$ W 8.2K $\Omega$
<b>PT</b>	<b>TRANSFORMER</b>			127	$\frac{1}{4}$ W 15K $\Omega$
1	52-51 (51-50)			123	$\frac{1}{4}$ W 22K $\Omega$
				121	$\frac{1}{4}$ W 27K $\Omega$
				109, 110	$\frac{1}{4}$ W 33K $\Omega$
<b>CT</b>	<b>CHOKE</b>			116	$\frac{1}{4}$ W 39K $\Omega$
1	50-11			133	$\frac{1}{4}$ W 47K $\Omega$
				101, 106, 108, 113, 131, 135	$\frac{1}{4}$ W 100K $\Omega$
				134	$\frac{1}{4}$ W 330K $\Omega$
<b>M</b>	<b>METER</b>			123	$\frac{1}{4}$ W 390K $\Omega$
1	KM-005				
				135	CARBON COMPOSITION $\frac{1}{8}$ W 100K $\Omega$
				134	$\frac{1}{8}$ W 330K $\Omega$
<b>SP</b>	<b>SPEAKER</b>			<b>VR</b>	<b>POTENTIOMETER</b>
1	SA-128		4 $\Omega$ 2W	102	EVL-S3A-B13 1KB
				101	EVL-S3A-B53 5KB
<b>S</b>	<b>SWITCH</b>			<b>C</b>	<b>CAPACITOR</b>
1	ATT	ESL-3037			CERAMIC
4	TONE	ESL-3037		159	50WV 1PF(CH)
2	BAND	ESR-E264R20		117, 138, 142, 146	50WV 2PF(CH)
3	MODE	ESR-E264R20		106, 109, 122, 160	50WV 3PF(CH)
5	POWER	8H2011		111, 130, 150	50WV 5PF(CH)
6	LAMP	8H2011		128, 131	50WV 10PF(CH)
				119	50WV 15PF(CH)
				129, 157, 158, 161	50WV 22PF(CH)
				110	50WV 27PF(CH)
<b>J</b>	<b>CONNECTOR</b>			107, 108	50WV 33PF(CH)
1	JSO-239			139, 143, 168	50WV 47PF(CH)
2	SQ-2450-03			124	50WV 82PF(CH)
3	SG-8050-07			114	50WV 100PF(SL)
4	SG-8414				







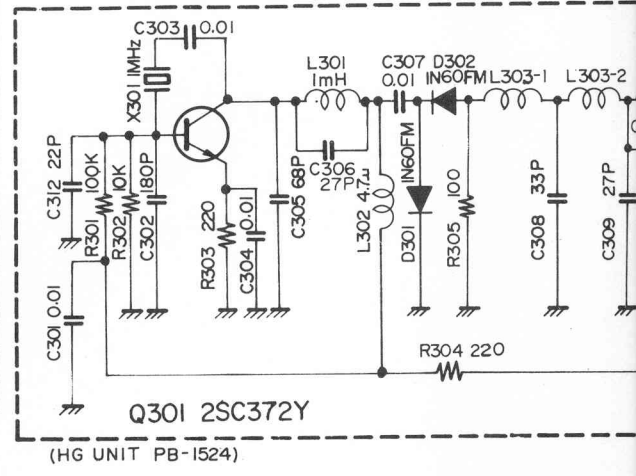
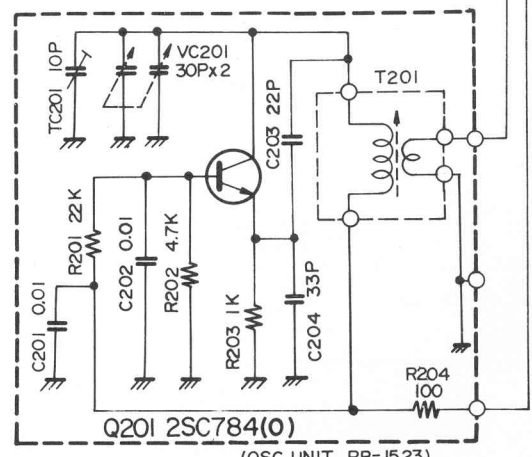
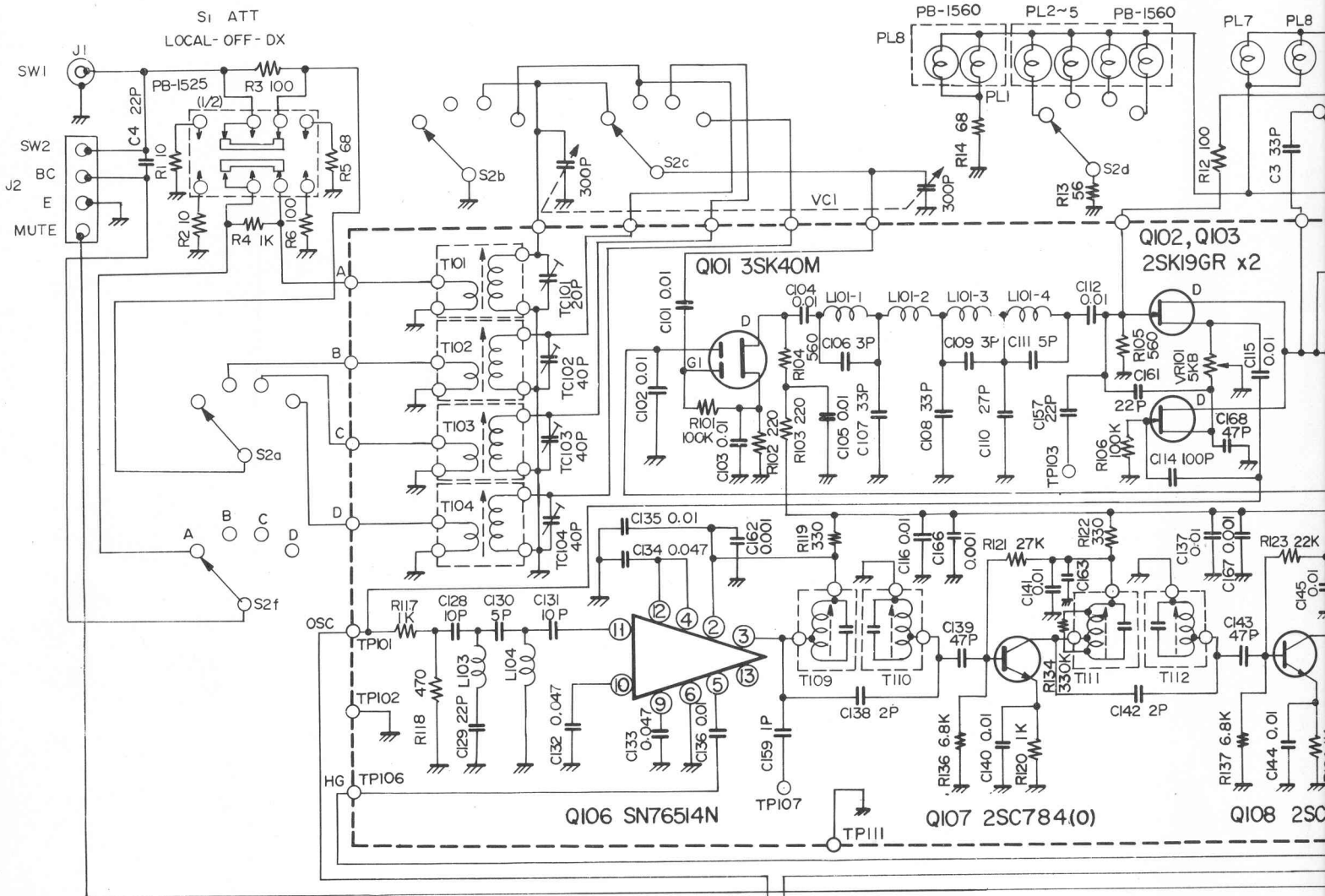

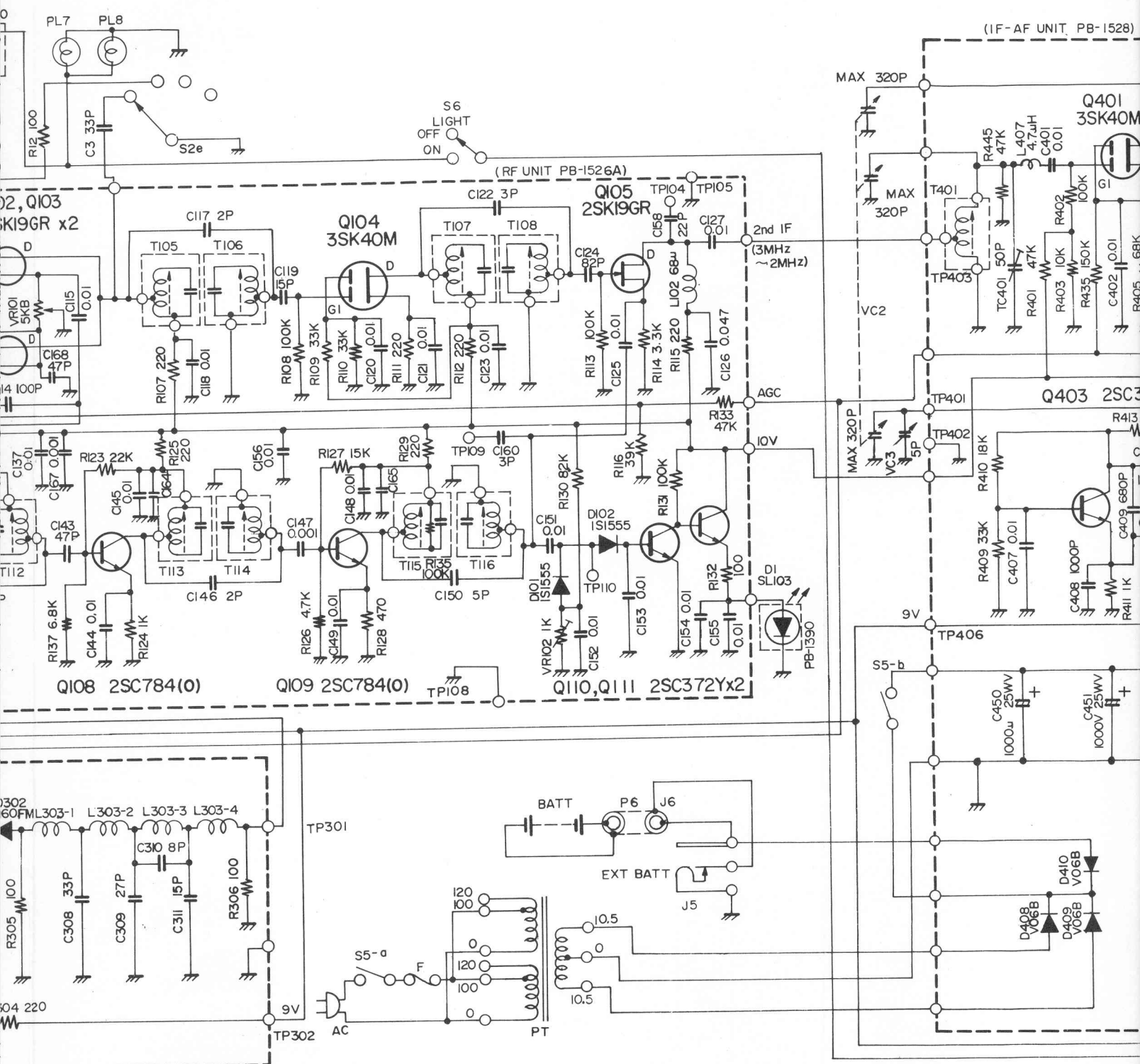



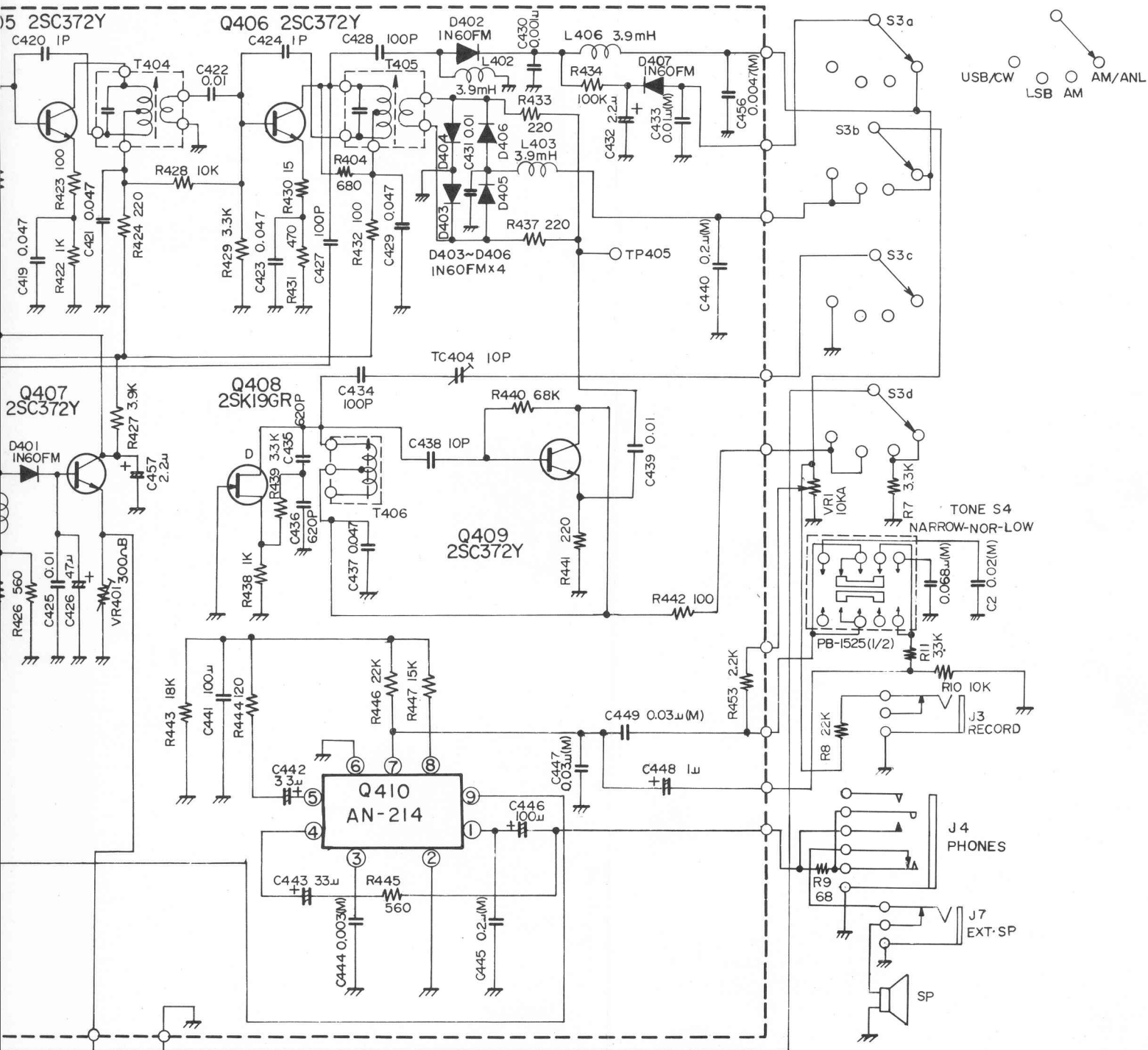

- NOTE
- 1 ALL RESISTORS ARE IN 1/4W UNLESS OTHERWISE NOTED.
  - 2 ALL CAPACITORS ARE IN µF UNLESS OTHERWISE NOTED.
  - 3 ALL ELECTROLYTIC CAPACITORS ARE 16WV UNLESS OTHERWISE NOTED.

**FRG-7**  
**CIRCUIT DIAGRAM**

